

○ ○ ○ ○ ○ LAST
STRAW

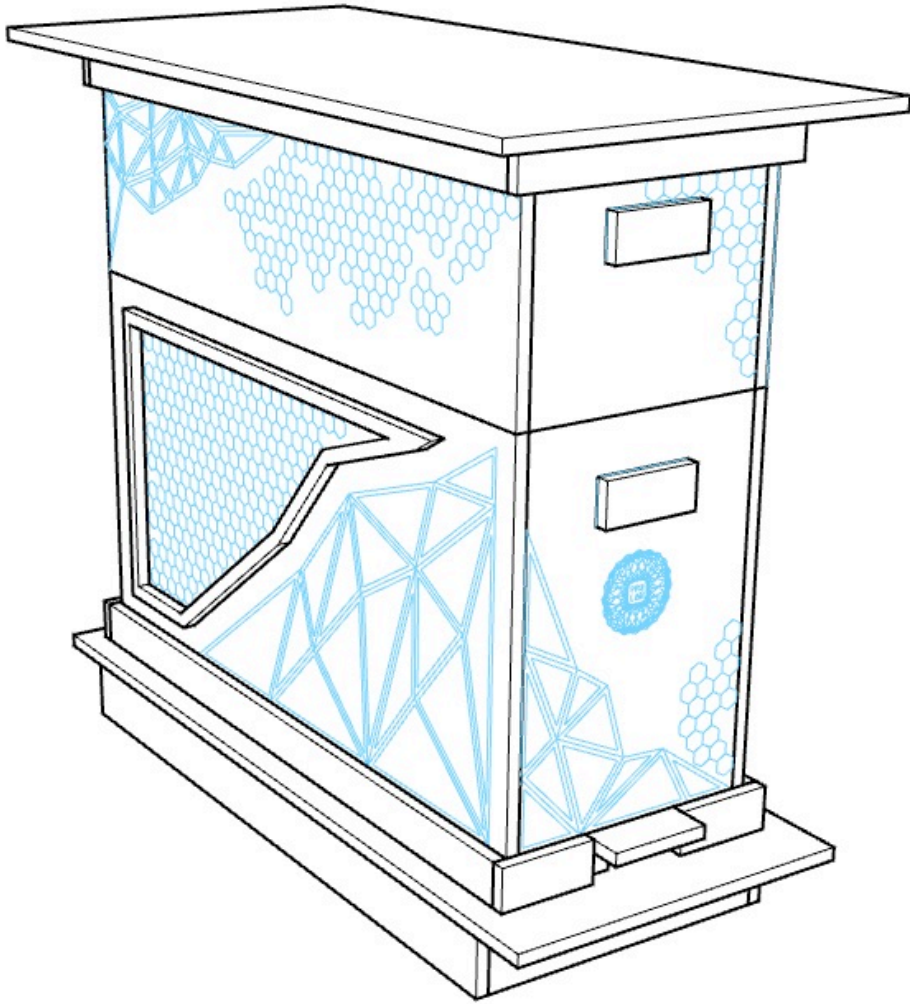

INTRODUCCIÓN Y PIEZAS DE PANALES



1. Descargar los planos de fabricación de la página:
www.laststraw.lat

2. Realizar la manufactura de las piezas ya sea por método de corte láser (recomendado) o de forma manual.

A continuación se muestran de forma gráfica las piezas necesarias a utilizar para el ensamble de los panales.



A x 6



B x 6

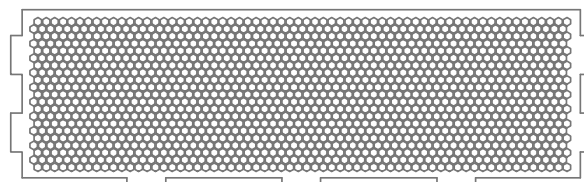

C x 12

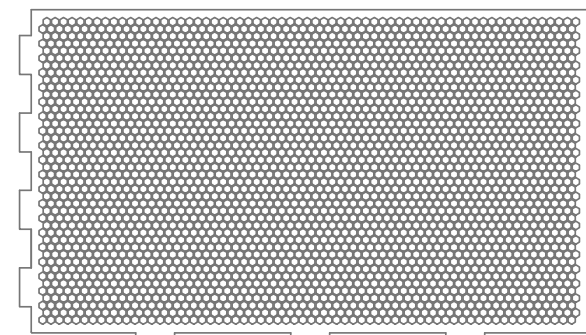

F x 12



D x 6



G x 6



E x 3

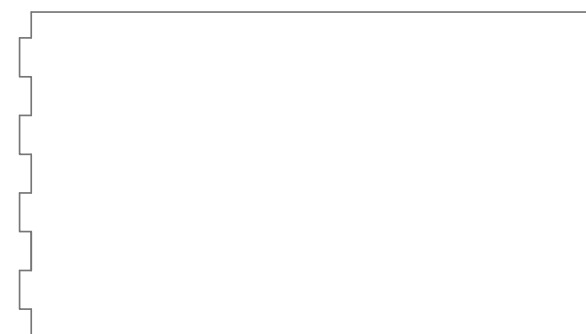

H x 3

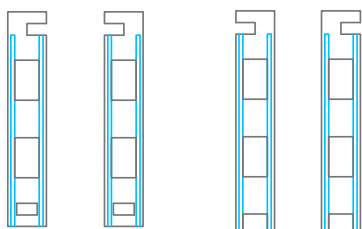

J x 3

K x 3

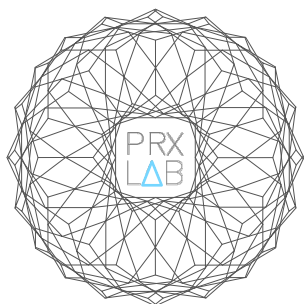

PIEZAS DE CÁMARA DE CRÍA

○ ○ ○ ○ ○ LAST
STRAW



A1



A2

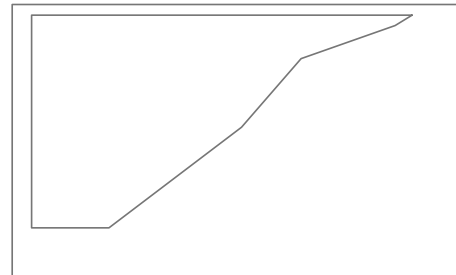

A3

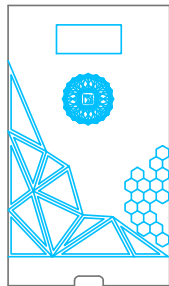

A4

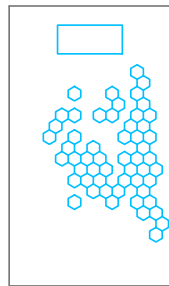

A5

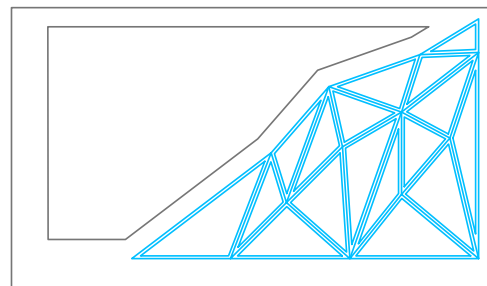

A6



A7

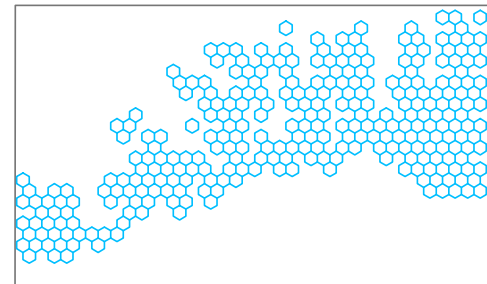

A8

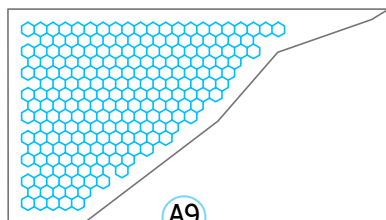

A9

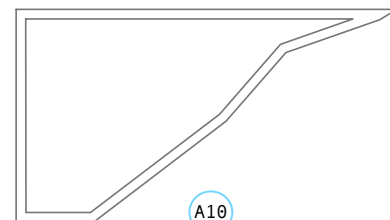

A10



A12

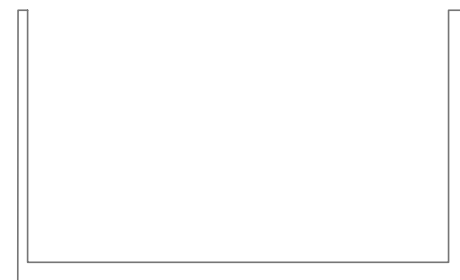

A11

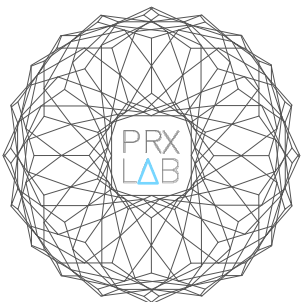

PIEZAS DE CÁMARA DE ALZA Y TAPA

○ ○ ○ ○ ○ LAST
STRAW

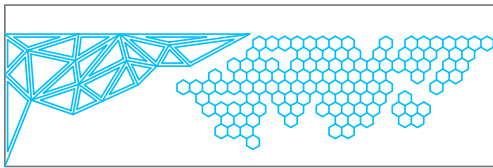

B1

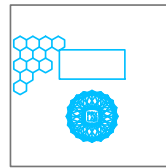

B2

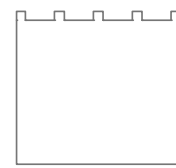

B3

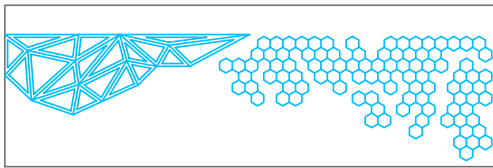

B4

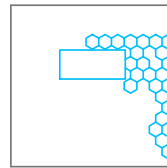

B5

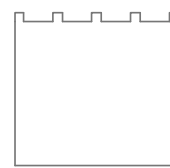

B6



B7

TAPA DE MADERA



C1

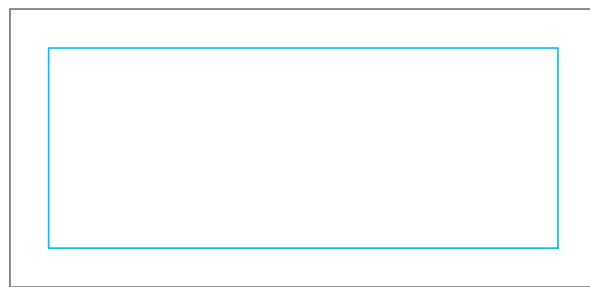

C2

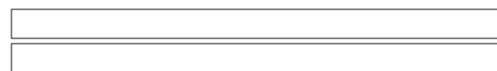

C3

TAPA DE ACRÍLICO

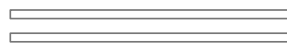

D1



D2

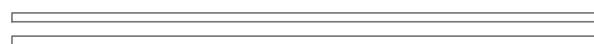

D3

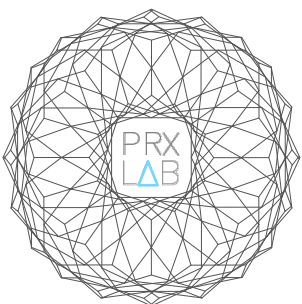

PIEZAS DE BASE DE COLMENA

○ ○ ○ ○ ○ LAST
STRAW

BASE DE MADERA

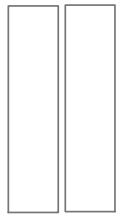

E1



E2



E7



E3



E4



E5

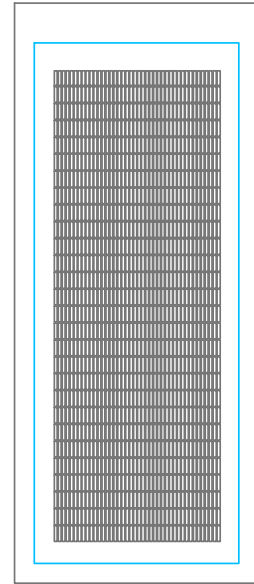

E6

BASE DE ACRÍLICO

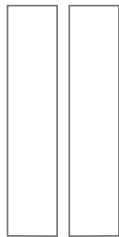

F1



F2

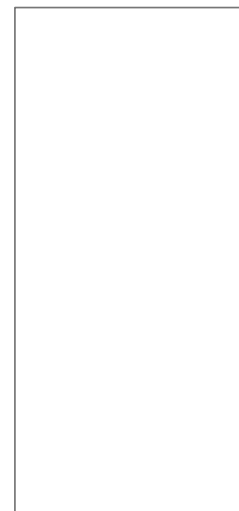

F3

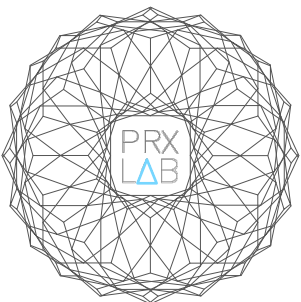

COMPONENTES DE PANAL

○ ○ ○ ○ ○ LAST
STRAW

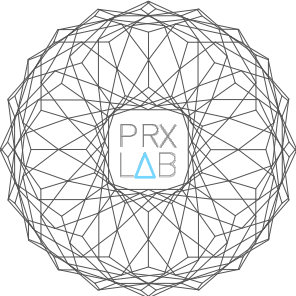
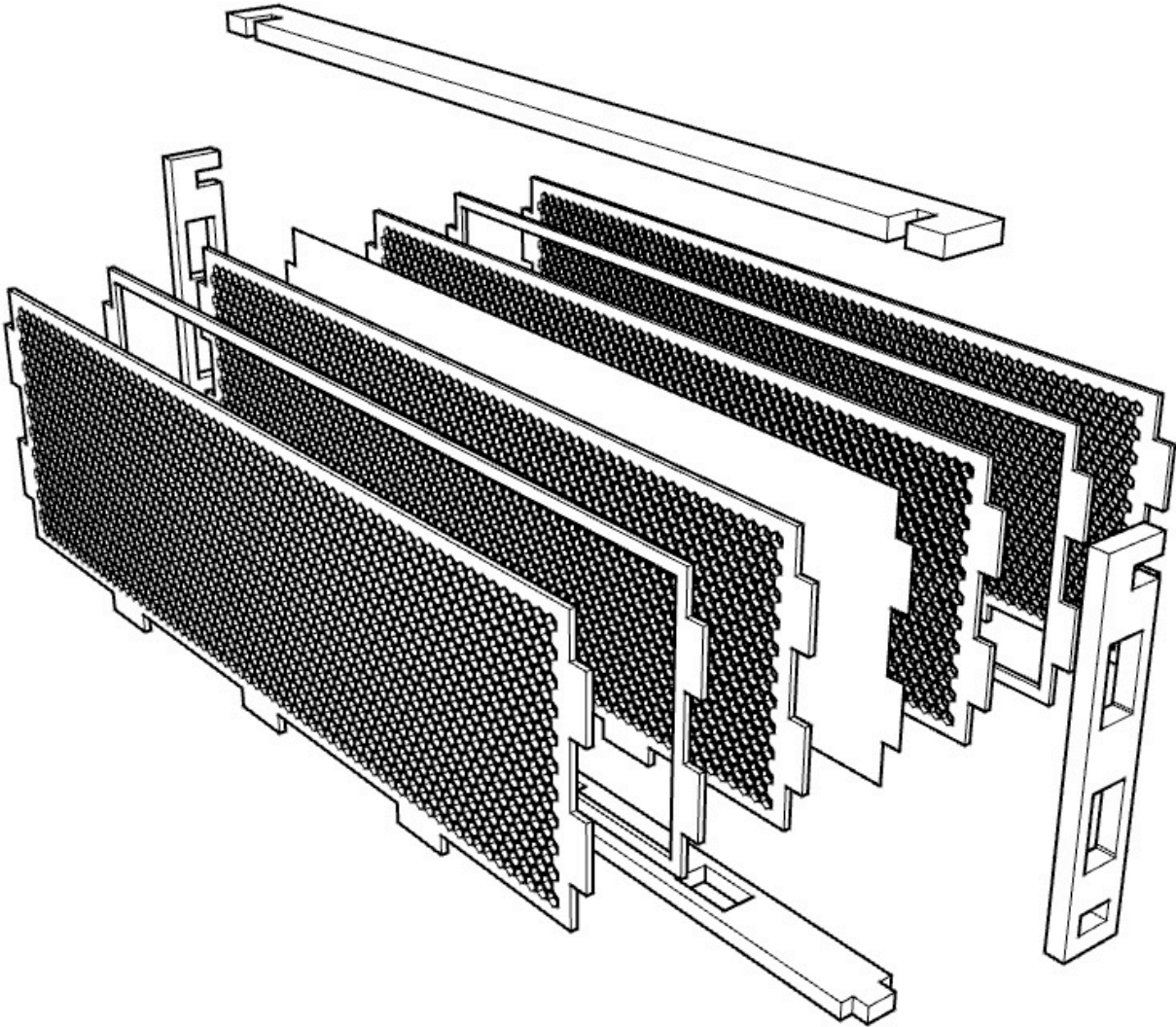

PIEZAS DE COMPONENTES EN PANAL

○ ○ ○ ○ ○ LAST
STRAW

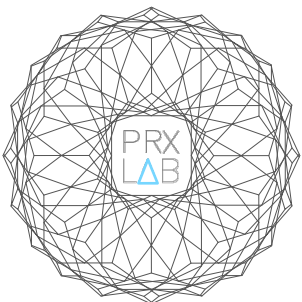
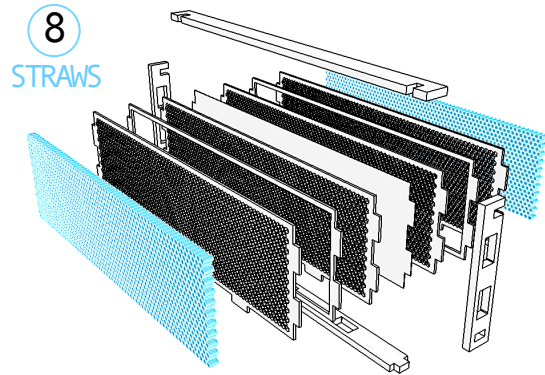
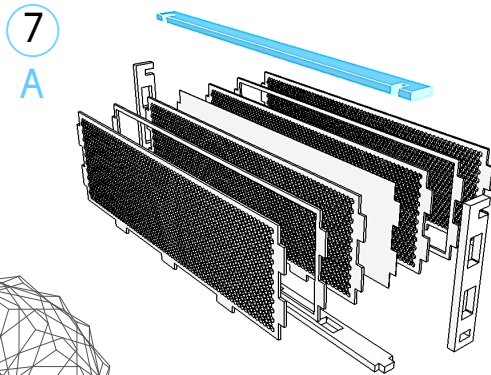
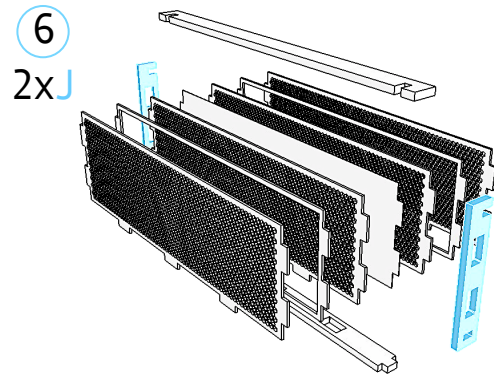
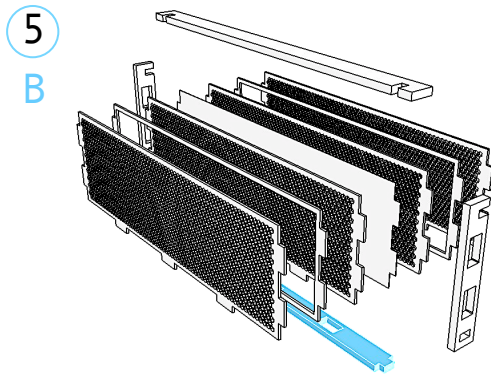
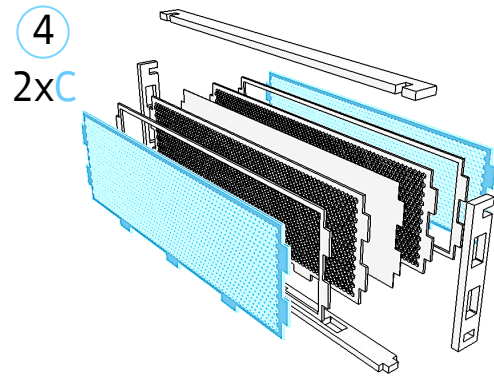
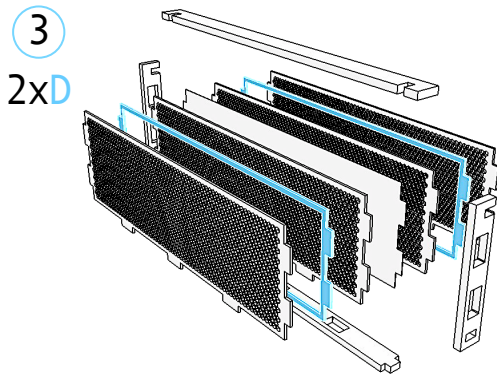
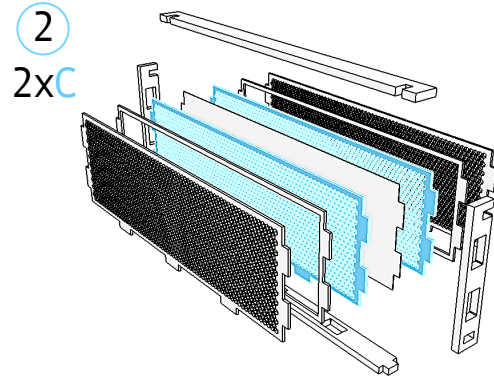
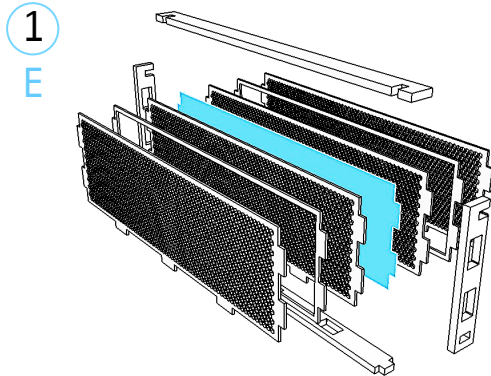

ENSAMBLE DE PANAL

○ ○ ○ ○ ○ LAST
STRAW

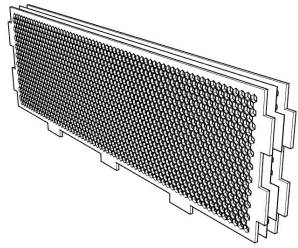

E+2xC

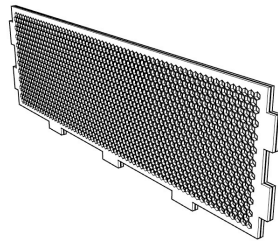

E+2C

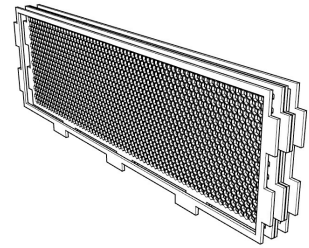

+2xD

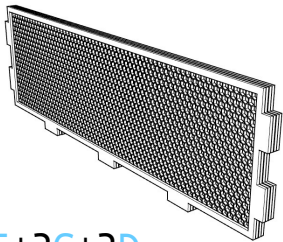

E+2C+2D

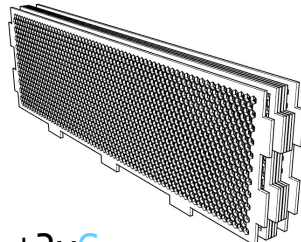

+2xC

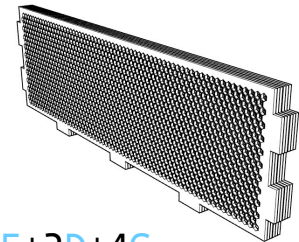

E+2D+4C

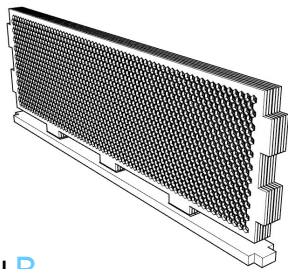

+B

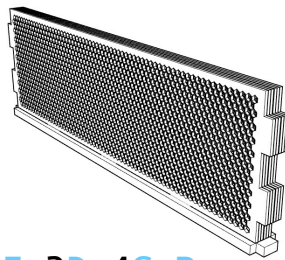

E+2D+4C+B

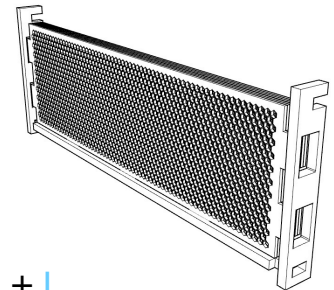

+J

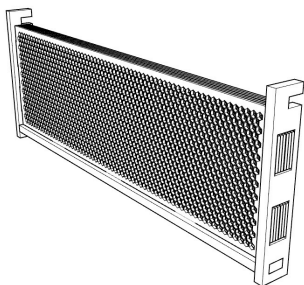

E+2D+4C+B+J

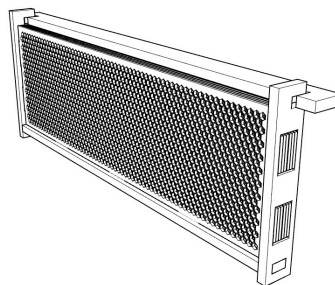

+A

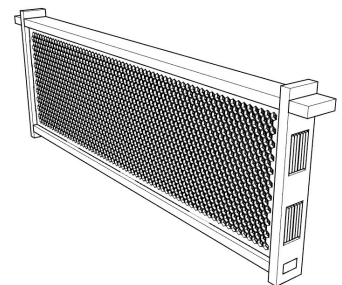

E+2D+4C+B+J+A

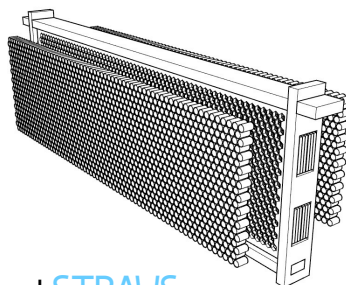

+STRAWS

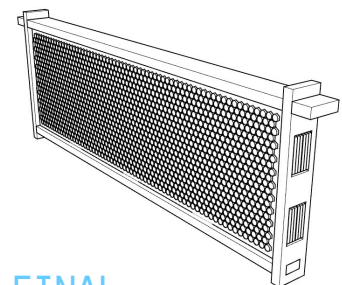

FINAL

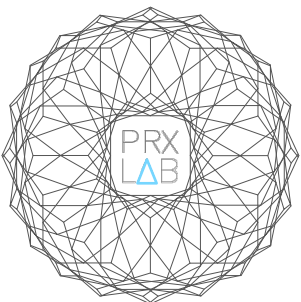

COMPONENTES DE COLMENA

○ ○ ○ ○ ○ LAST
STRAW

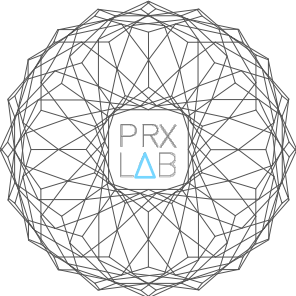
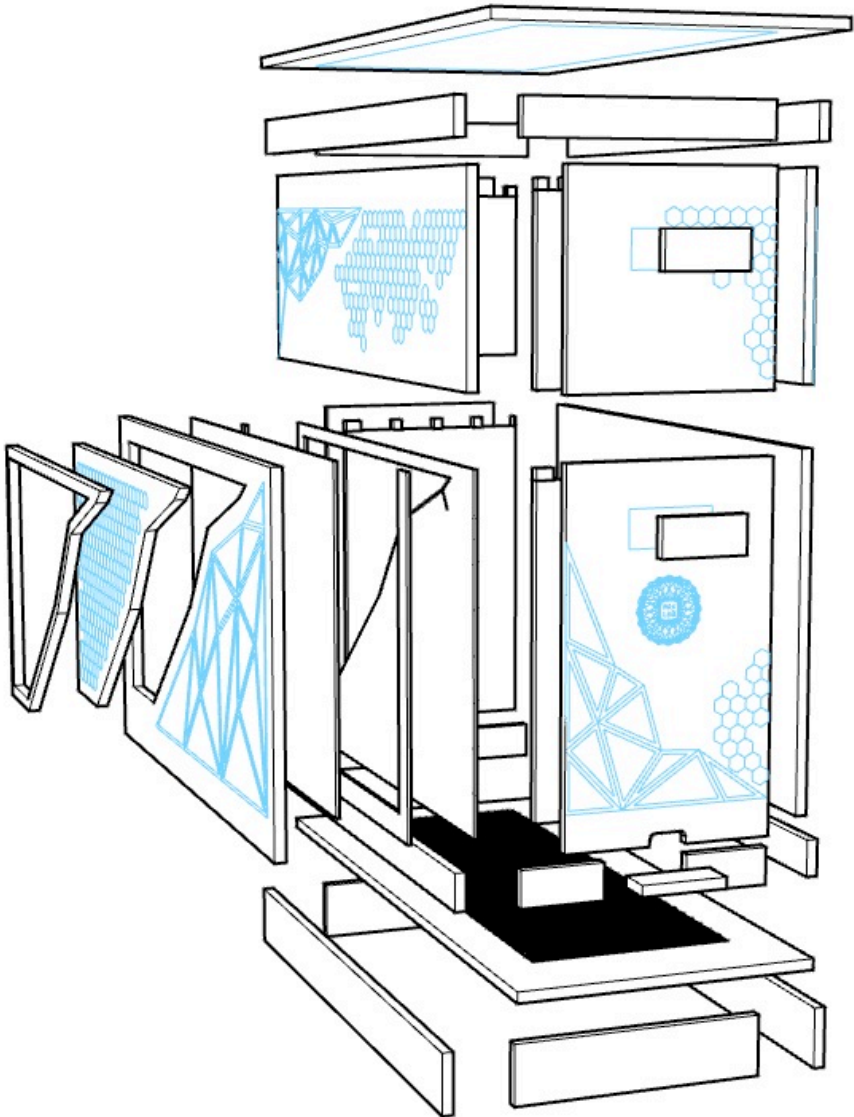

PIEZAS DE COMPONENTES EN COLMENA

LAST STRAW

TAPA

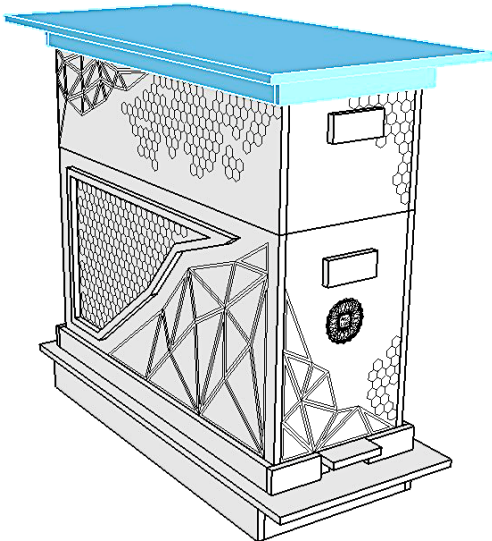

CÁMARA DE ALZA

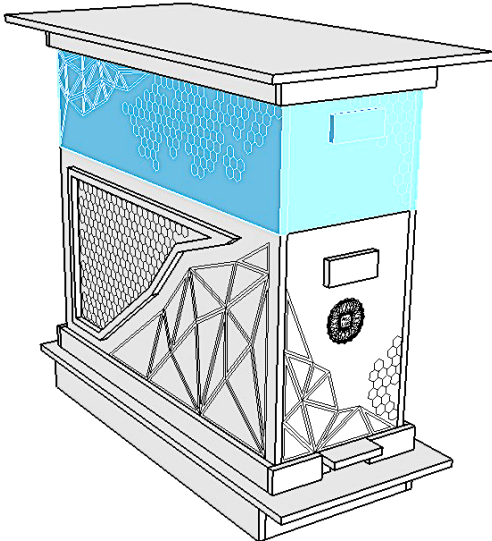

CÁMARA DE CRÍA

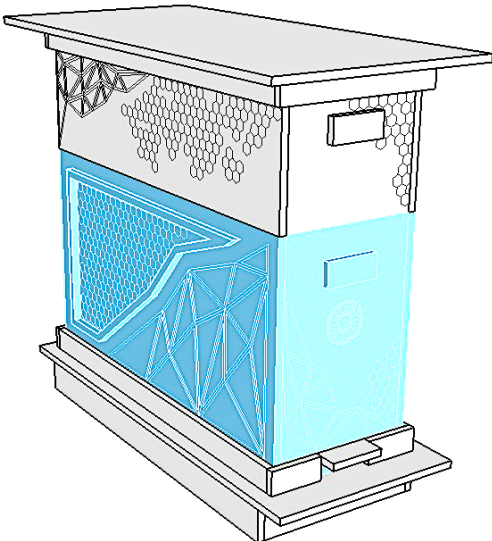

BASE

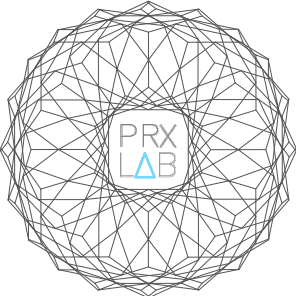
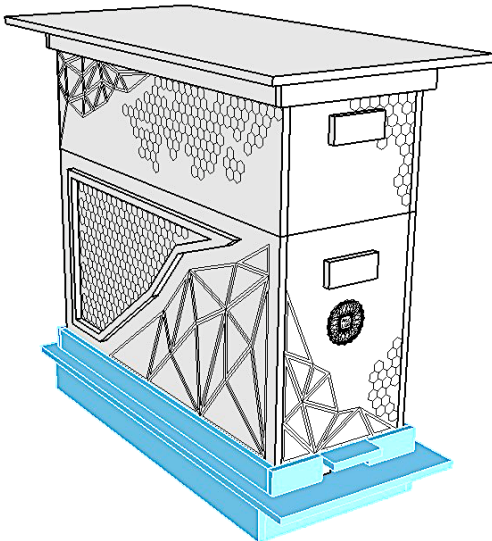

COMPONENTES DE TAPA DE COLMENA

○ ○ ○ ○ ○ LAST
STRAW

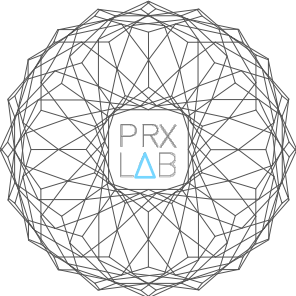
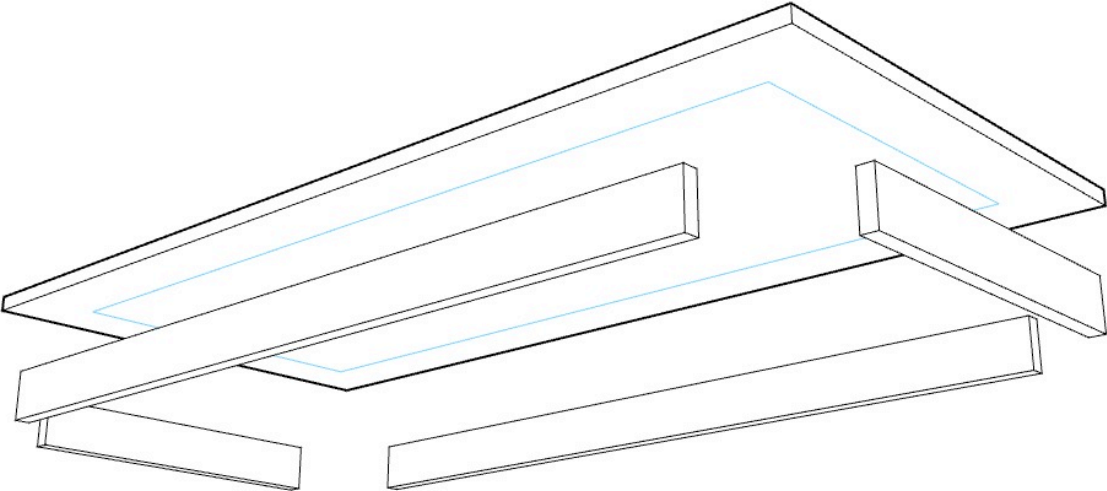

PIEZAS DE COMPONENTES Y ENSAMBLE DE TAPA DE COLMENA

○ ○ ○ ○ ○ LAST STRAW

①
C2

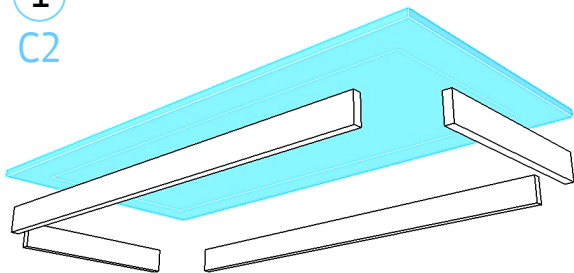

②
2xC3

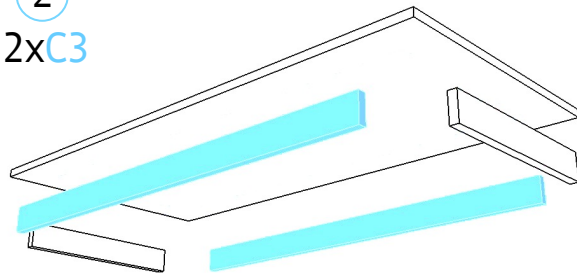

③
2xC1

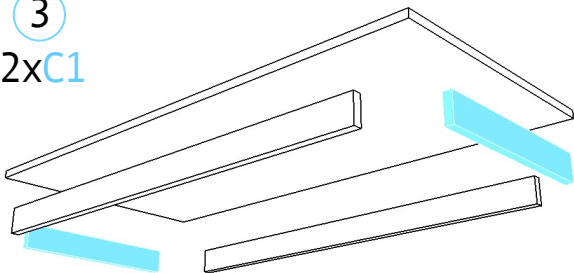

C2

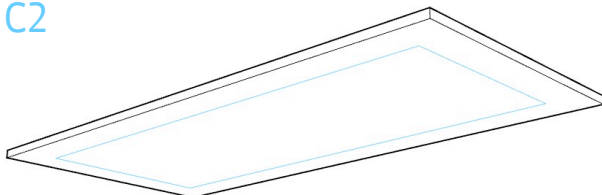

C2+2xC3

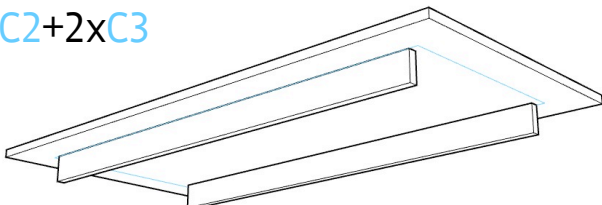

C2+2xC3+2xC1

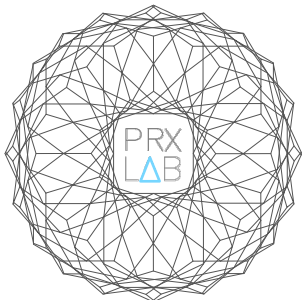
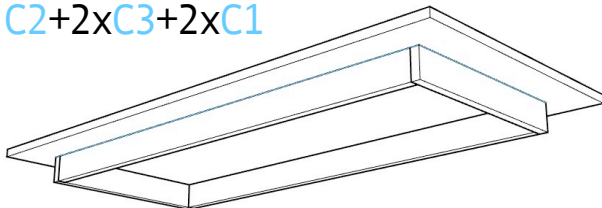

COMPONENTES DE CÁMARA DE ALZA

○ ○ ○ ○ ○ LAST
STRAW

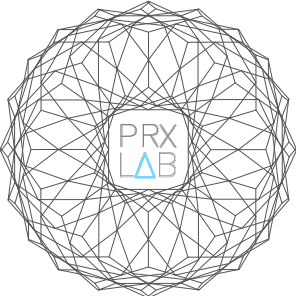
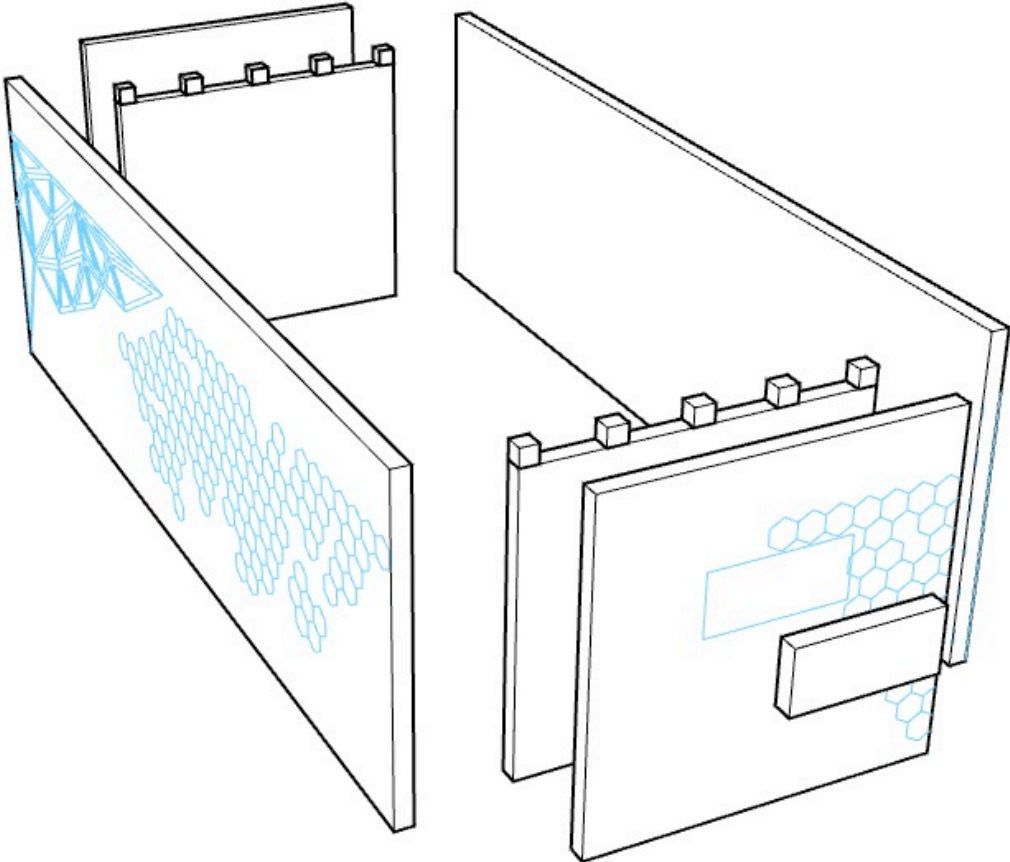

PIEZAS DE COMPONENTES Y ENSAMBLE DE CÁMARA DE ALZA

○ ○ ○ ○ ○ LAST STRAW

①
B3+B6

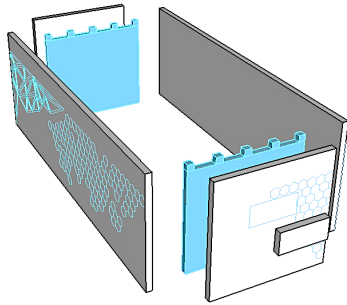

②
B1+B4

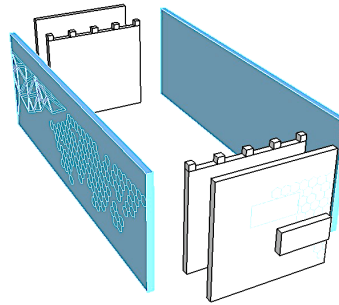

③
B2+B5

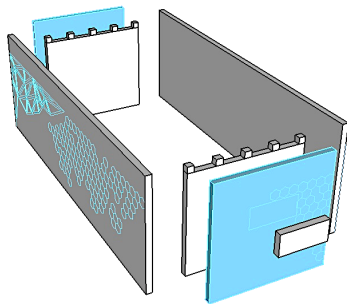

④
2xB7

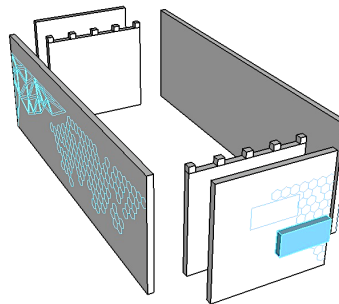

B3+B6

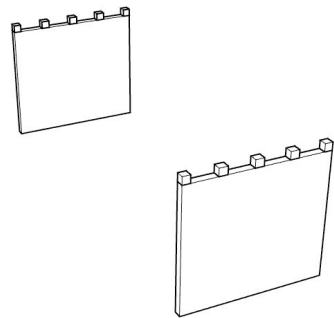

B3+B6+
B1+B4

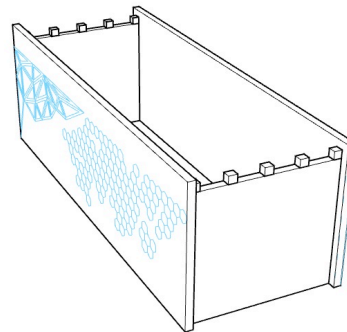

B3+B6+
B1+B4+
B2+B5+

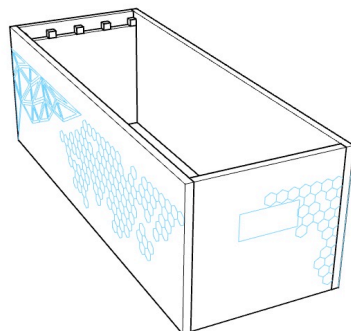

B3+B6+
B1+B4+
B2+B5+
2xB7

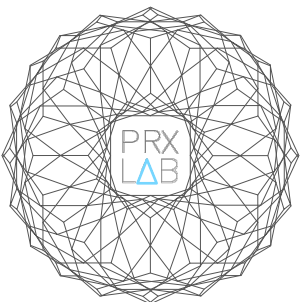
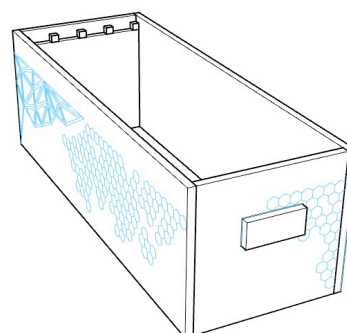

COMPONENTES DE CÁMARA DE CRÍA

LAST STRAW

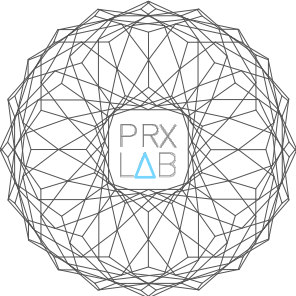
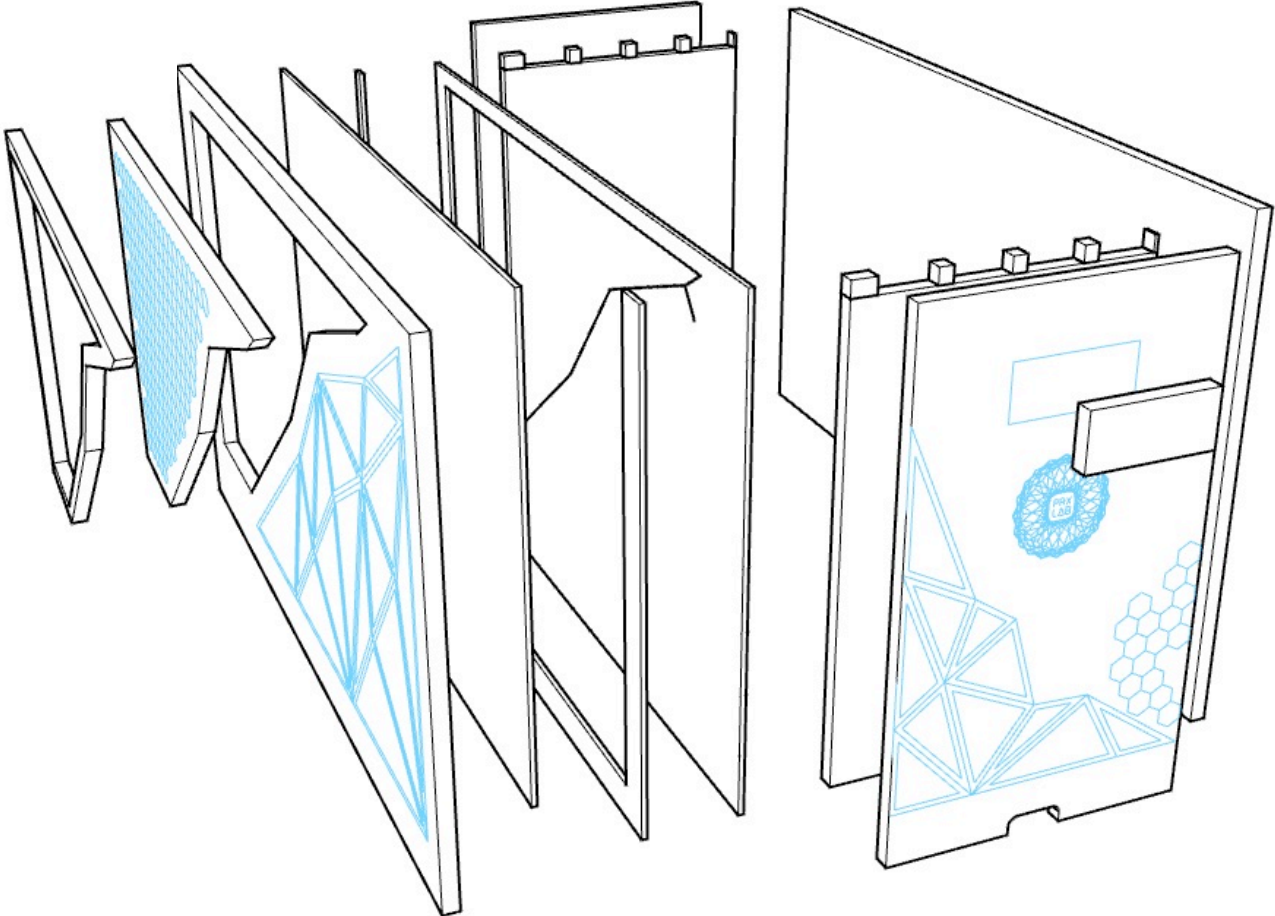

PIEZAS DE COMPONENTES EN CÁMARA DE CRÍA

○ ○ ○ ○ ○ LAST
STRAW

1

A1+A2

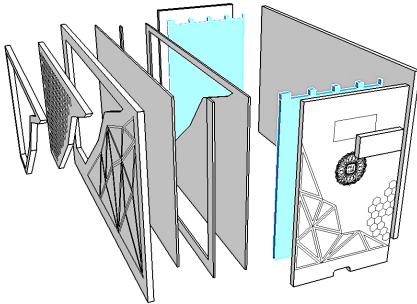

2

A4+A5

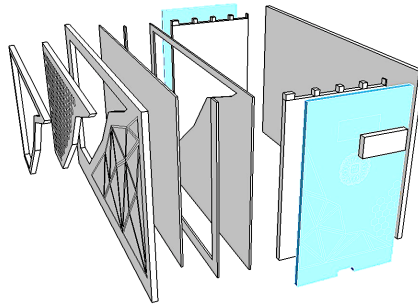

3

A6+A8

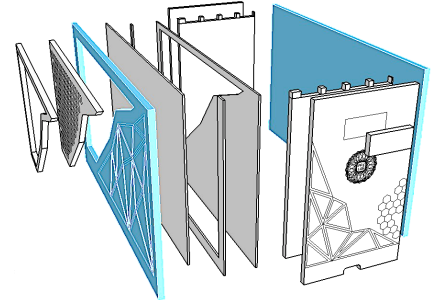

4

A3

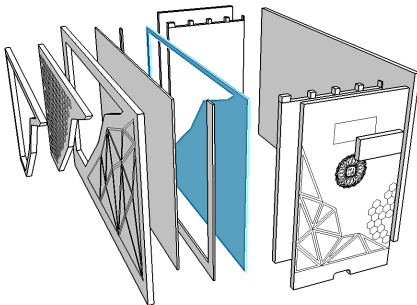

5

A11

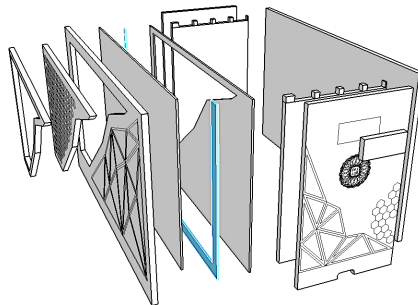

6

A7

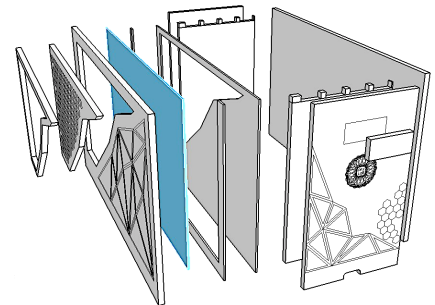

7

A9

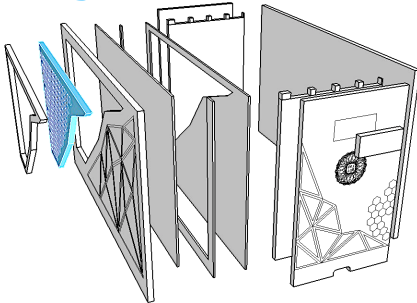

8

A10

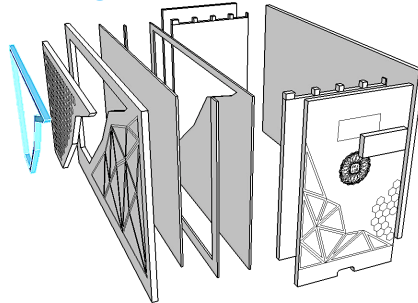

9

2x A12

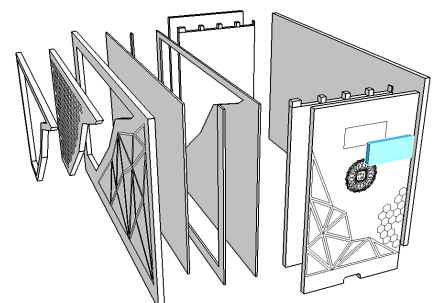

ENSAMBLE DE CÁMARA DE CRÍA

○ ○ ○ ○ ○ LAST
STRAW

A1+A2

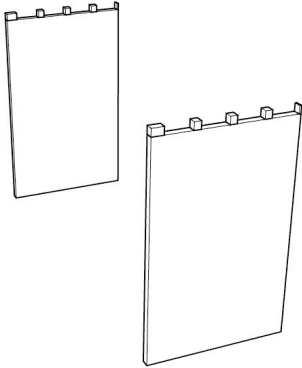

A1+A2+A4+A5

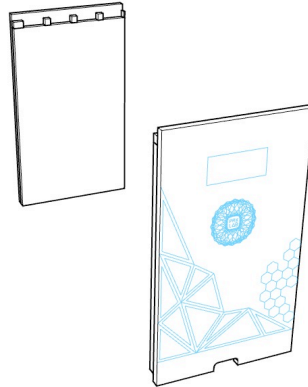

A1+A2+A4+A5+A3

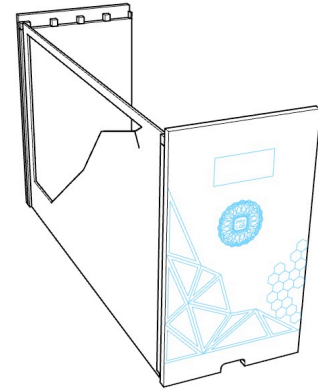

A1+A2+A4+A5+A3+A11

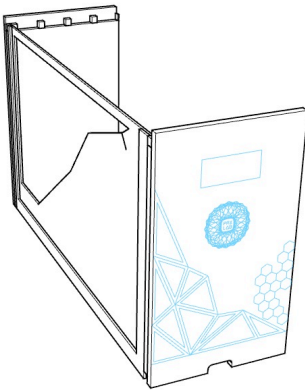

A1+A2+A4+A5+A3+A11+A7

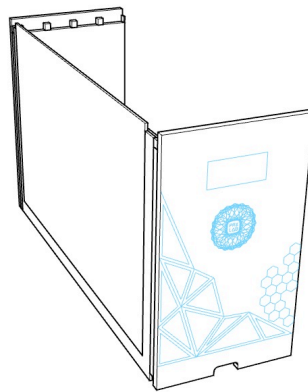

A1+A2+A4+A5+A3+A11+A7+A6+A8

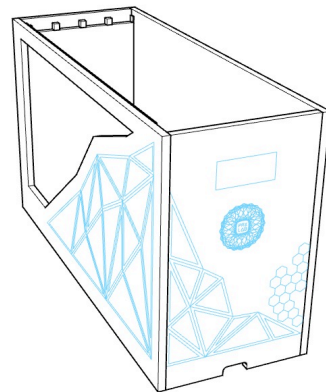

A1+A2+A4+A5+A3+A11+A7+A6+A8+A9

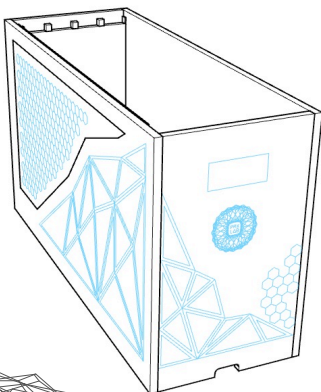

A1+A2+A4+A5+A3+A11+A7+A6+A8+A9+A10

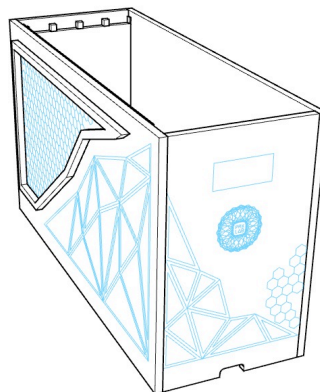

A1+A2+A4+A5+A3+A11+A7+A6+A8+A9+A10+2x A12

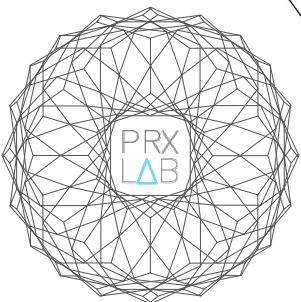
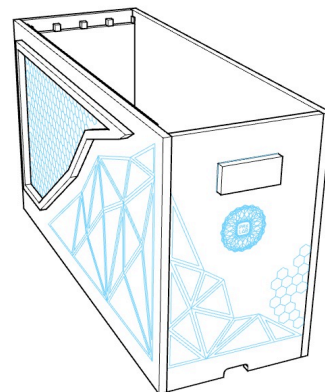

COMPONENTES DE BASE DE COLMENA

○ ○ ○ ○ ○ LAST
STRAW

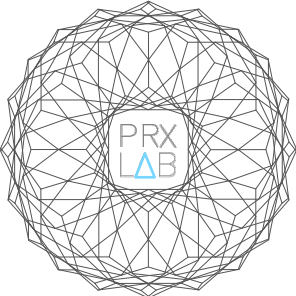
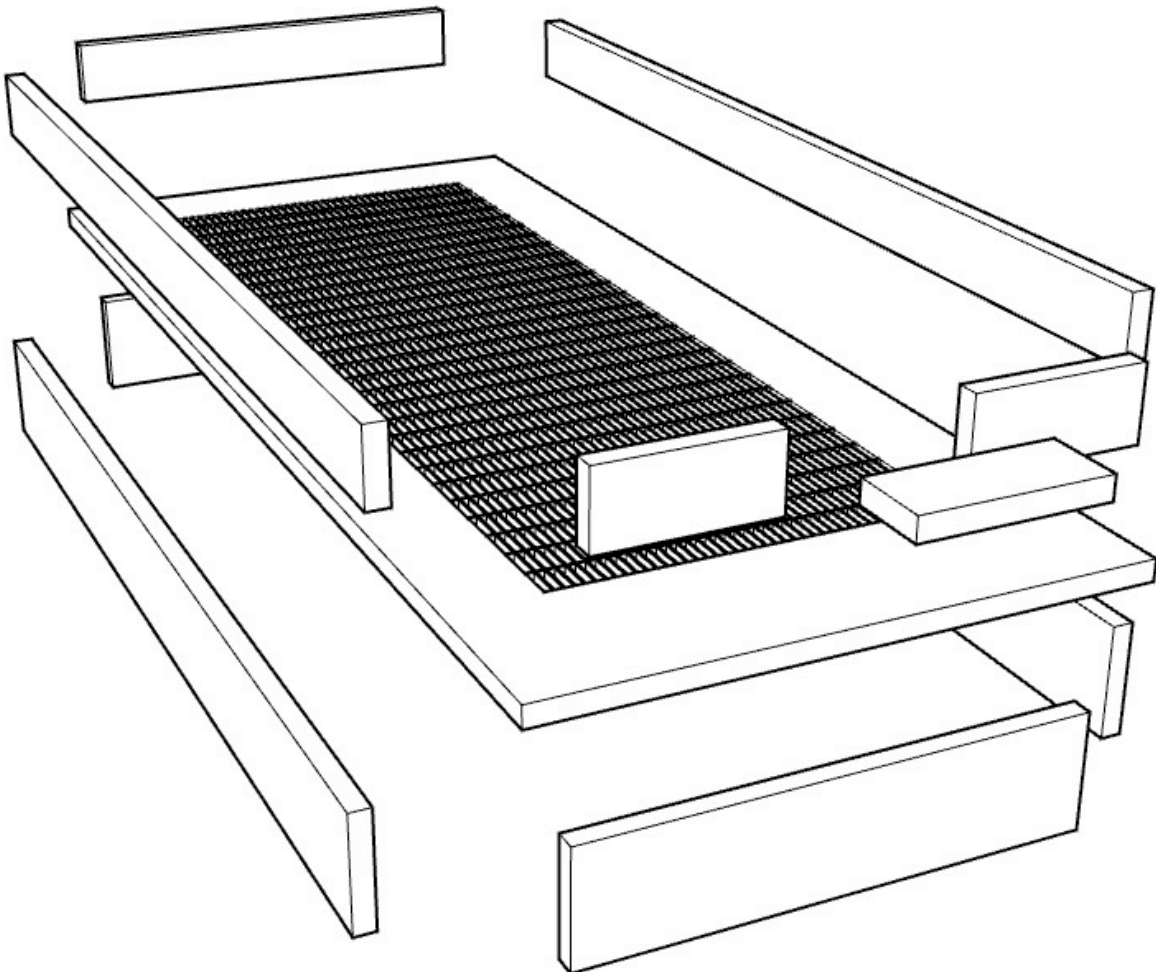

PIEZAS DE COMPONENTES EN BASE DE COLMENA

○ ○ ○ ○ ○ LAST
STRAW

1
E6

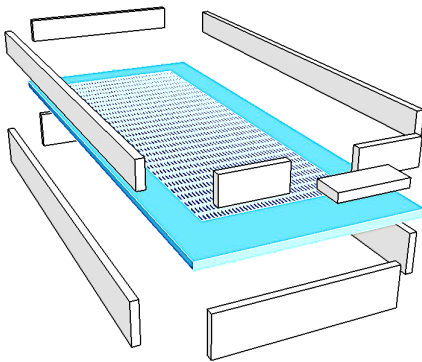

2
2xE5

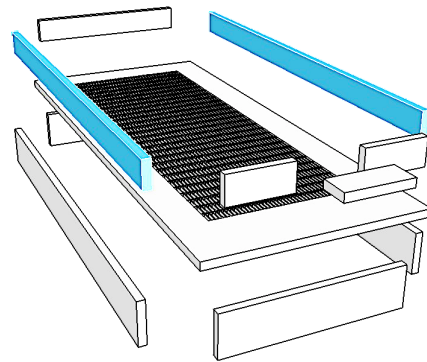

3
E3

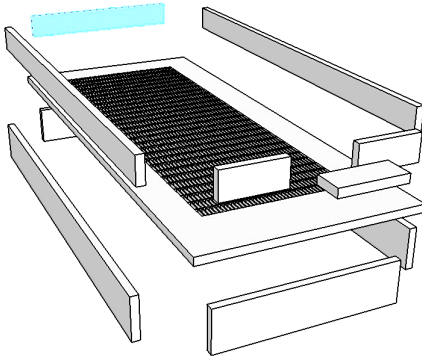

4
2xE2

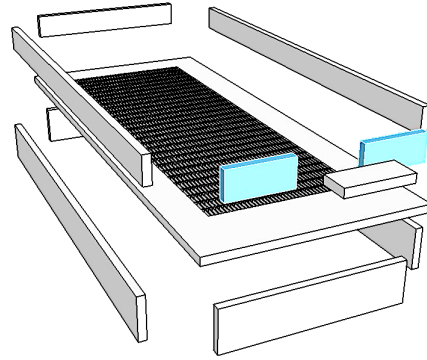

5
E7

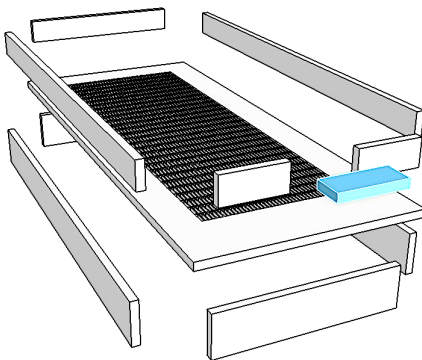

6
2xE1

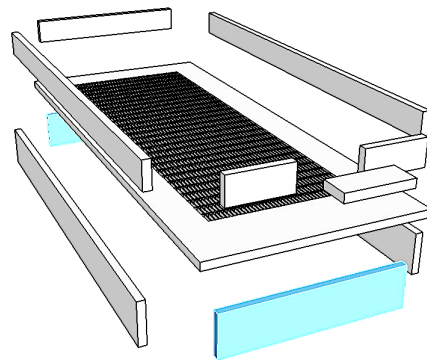

7
2xE4

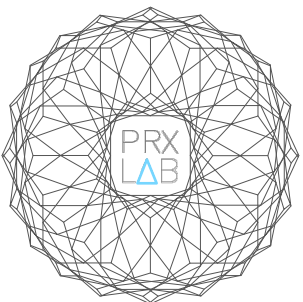
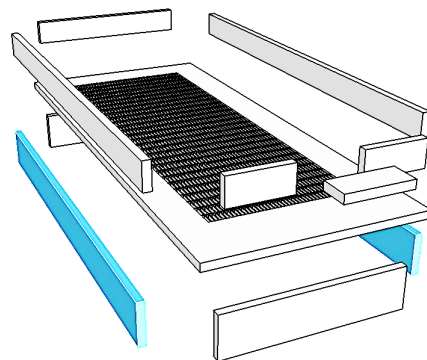

ENSAMBLE DE BASE DE COLMENA

○ ○ ○ ○ ○ LAST
STRAW

E6

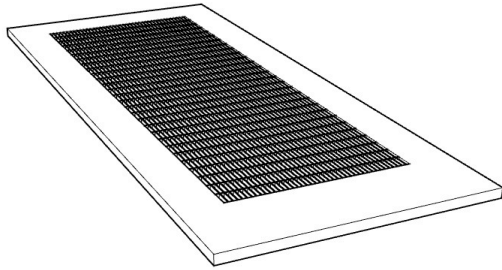

E6+2xE5

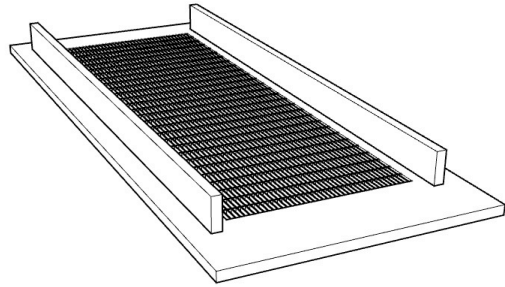

E6+2xE5+E3

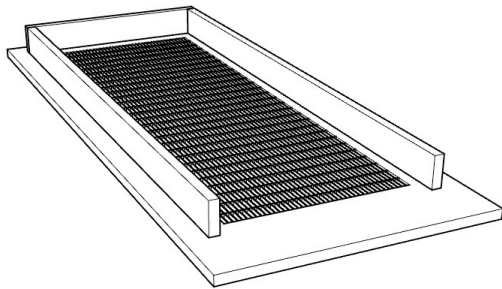

E6+2xE5+E3+2xE2

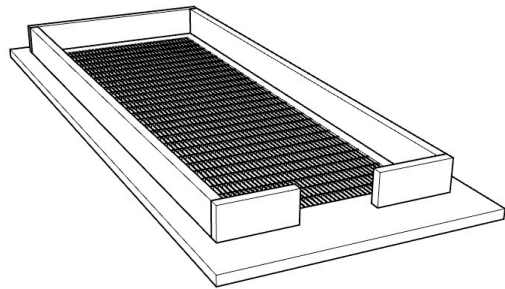

E6+2xE5+E3+2xE2+E7

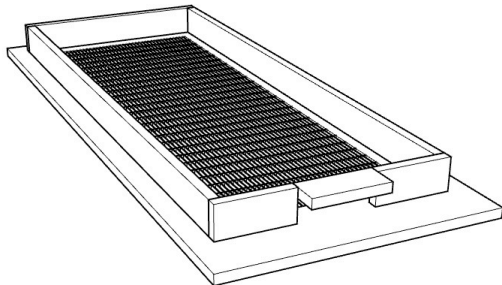

E6+2xE5+E3+2xE2+E7+2xE1

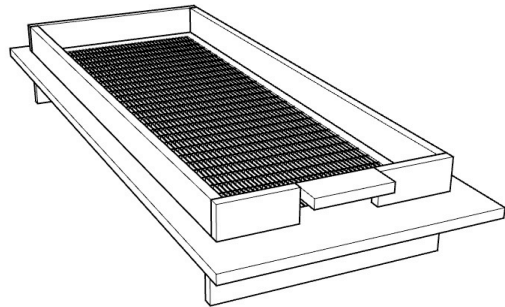

E6+2xE5+E3+2xE2+E7+2xE1+2xE4

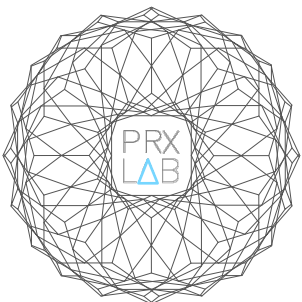
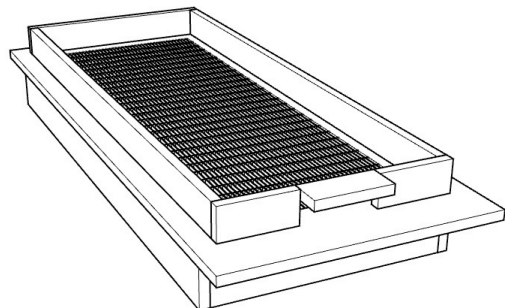

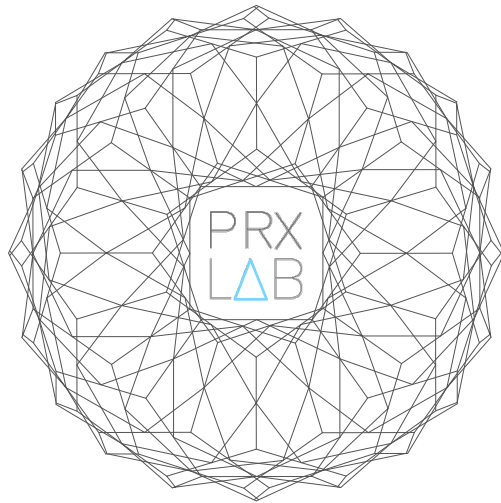

PRAXIS LABORATORY FOR DIGITAL FABRICATION